

FLO-WashPress

FWP

Washer Compactor

A Flexible, Low Profile Screenings Washing and Dewatering System



Two Flo-WashPress units receiving screenings from a conveyor system.

The Flo-WashPress Shafted Washer Compactor incorporates screenings washing and dewatering in a single unit. The clean, dewatered screenings can then be discharged into a dumpster or an optional continuous bagger for ease of handling and disposal.



Flo-WashPress receiving screenings from an Enviro-Care Flo-Screen

Features & Benefits

- 1 **Screenings washing** - Removing organics from screenings prior to dewatering produces drier solids.
- 2 **35% to 40% dry solids** - More acceptable to landfill.
- 3 **Clean, dewatered screenings** - Reduced volume and less odor.
- 4 **Less odor** - More neighbor and operator friendly.
- 5 **75% volume reduction** - Reduced handling and disposal costs.
- 6 **Compact, low profile design** - Easily retrofitted into existing installations or integrated into new equipment layouts.

As with all products in the Enviro-Care Flo-Products family, the Flo-WashPress keeps mechanical complexity to a minimum. With its low maintenance, single auger screw design and its efficient drive system, the Flo-WashPress Shafted Washer Compactor significantly reduces maintenance requirements and downtime.

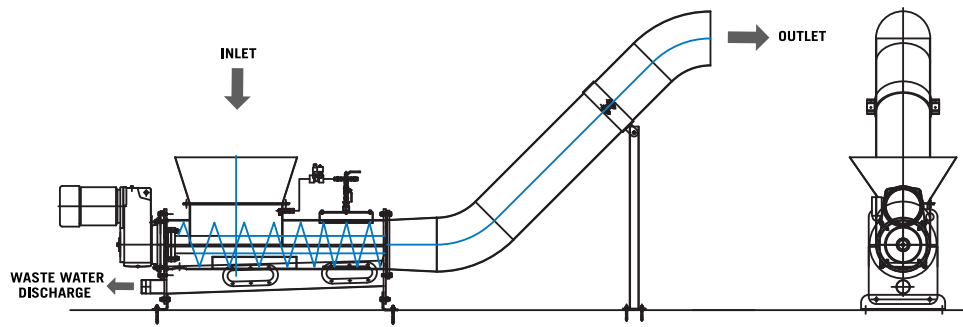

Specifications

		FWP-1	FWP-2	FWP-3
Nominal tube size	DN	200	250	300
Capacity	CuFt	70	125	210
Volume reduction	%	>65%	>65%	>65%
Drive motor	Hp	5	5	7.5
Controls		NEMA 4x/7	NEMA 4x/7	NEMA 4x/7
Pressure	bar	5	5	5

Materials of Construction

Covers	AISI 304 SST (316 Optional)
Transport tube	AISI 304 SST (316 Optional)
Chutes	AISI 304 SST (316 Optional)
Fasteners	AISI 304 SST (316 Optional)
Shafted screw	ST52-3 Alloy Steel (304/316 SST Optional)

FLO-Products

Simply Superior Design

Enviro-Care has been manufacturing liquid/solid separation and solids reduction technology for the wastewater industry since 1972. Many of these first units are still in service today. These unique products are engineered for high process efficiency, reduced maintenance and low energy consumption.

The Enviro-Care Flo-Products family is expanding. With the addition of new screens, MBR Pre-treatment systems, washing and dewatering options and complete septage receiving systems; Enviro-Care products can be found providing the same exceptional quality and cost-effective technology in more wastewater applications than ever before.

Flo-Drum MBR Pre-treatment Screen

Flo-Drum Rotating Screen

Flo-Minutor Solids Reduction Comminutor

Flo-MultiRake Coarse Bar Screen

Flo-MultiRake Fine Bar Screen

Flo-MultiRake Perforated Media Screen

Flo-Press Hydraulic Ram Press

Flo-Screen Bar Screen

Flo-Screen XD Extended Discharge Bar Screen

Flo-Sieve Shaftless Spiral Screening

Conveying, Washing and Dewatering System

Flo-Spiral Shaftless Spiral Conveyor

Flo-Station SR Septage Receiving System

Flo-WashPress Washer Compactor